

**HLS-700**

## Brass Auto Air Vent - PN10

**Product Features**

- Removes inevitable potentially dangerous air trapped in system
- Simplifies the venting process
- Saves time and costs
- Conforms to design standard BS EN 1074-4

**Pressure/Temperature Ratings**

TEMPERATURE (°C)	-10 to 50	70
PRESSURE (BAR)	10	7

Intermediate pressure ratings shall be determined by interpolation.

**Materials**

NO.	PART	MATERIAL
1	Cap	Brass BS EN 12164 CW614N
2	Stem	Brass BS EN 12164 CW614N
3	Gasket	NBR
4	Spring	Stainless Steel
5	O Ring	NBR
6	Air Cap	Brass BS EN 12164 CW614N
7	Gasket	NBR
8	Core	Brass BS EN 12164 CW614N
9	Body	Brass BS EN 12164 CW614N
10	Floater	Polytene
11	Floater Bar	Brass BS EN 12164 CW614N
12	Connector	Brass BS EN 12164 CW614N
13	Spring	Stainless Steel 304
14	Disc	Brass BS EN 12164 CW614N

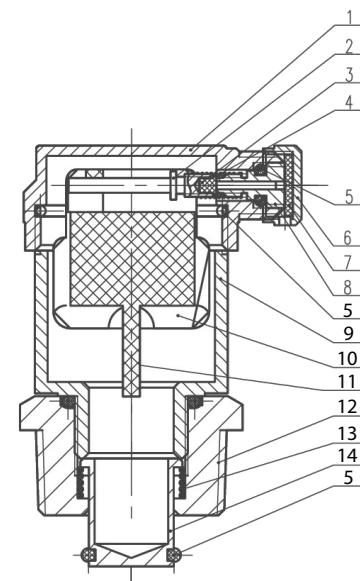

**HLS-700**

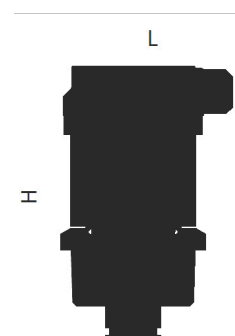
**Dimensions & Weights**

SIZE (inch)	L (mm)	H (m m)
1/2	50	68
3/4	50	68
1	50	68

**PRESSURE RATING :** PN10

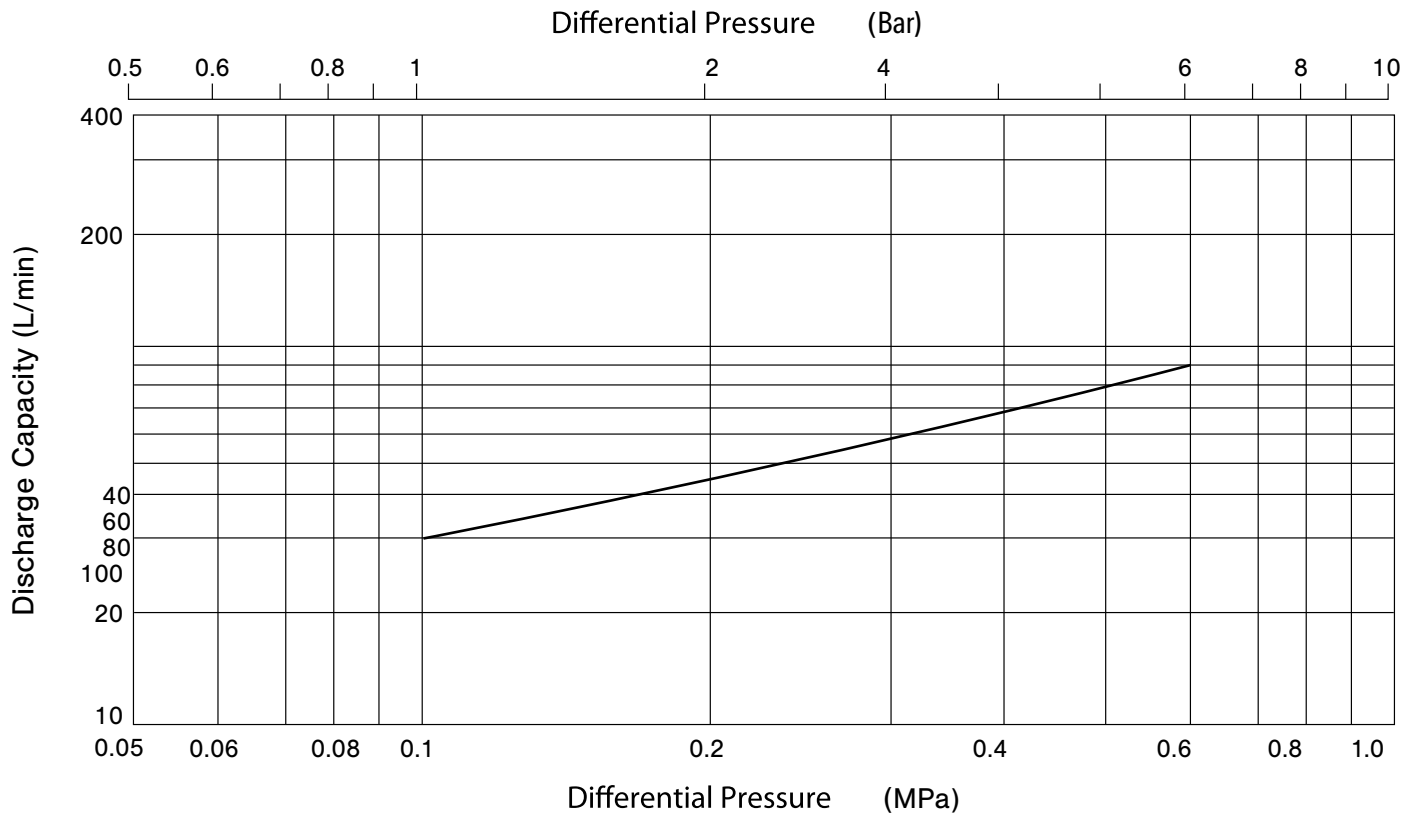
**TEMPERATURE OPERATING RANGE :** -10° to 70°C

**END CONNECTION :** Taper threaded to BS EN 10226-2 (ISO 7-1) formerly BS 21



1. Differential pressure is the difference between the inlet and outlet pressure of the air vent.
2. Capacities are equivalent capacities of air at 20 °C under atmospheric pressure.