

HLS-400 Brass Swing Check Valve - PN16

Product Features

- Check valves permit flow in one direction only and close automatically if flow reverses
- Horizontal swing pattern
- Robust and high quality bronze body



HLS-400
Pressure/Temperature Ratings

TEMPERATURE (°C)	-10 to 100	170
PRESSURE (BAR)	16	8

Interpolation shall be used to calculate intermidate pressure rating.

Materials

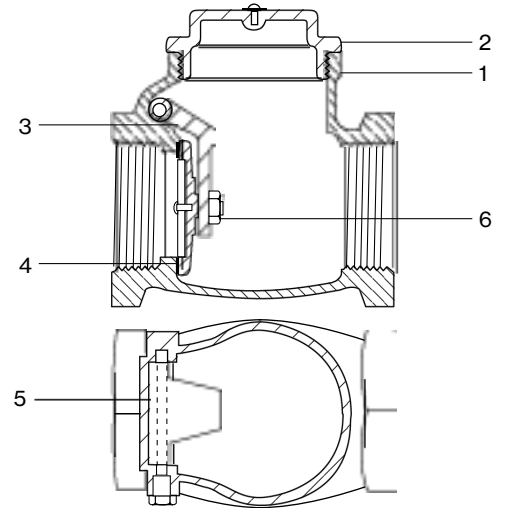
NO.	PART	MATERIAL
1	Body	Brass CW617N
2	Cap	Brass CW617N
3	Hinge	Brass CW617N
4	Disc	Brass CW617N
5	Hinge Pin	Stainless Steel
6	Hinge Nut	Brass CW617N

Dimensions

SIZE (inch)	d(mm)	L(mm)	H(mm)
1/2	13	50	35
3/4	19	60	40
1	25	74	47
1 1/4	30	84	53
1 1/2	36	94	60
2	46	114	70

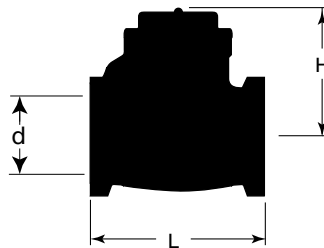

PRESSURE RATING : PN16

TEMPERATURE OPERATING RANGE : -10 to 170°C

END CONNECTION : Taper threaded to ISO 228